

H Connecting the A-191 to the system bus requires an **additional special power supply (+5 V / 50 mA)**.

1. Introduction

Module **A-191** is a **combination** of a **MIDI-CV interface** and a **Shepard Generator**. Most of the controls, indicators and in/outputs have a double function; there is a switch which toggles between the two sets of functions.

In use as a **MIDI-CV interface**, **13** of the 16 control voltage outputs are dedicated to sending voltages converted **from a particular MIDI controller** (such as Mod Wheel, Volume, Pitch Wheel, Aftertouch, etc.). Controller messages on your **chosen MIDI channel** are converted into voltages in a range from 0 to 5 V. The other three sockets output an **internal LFO** generated in sync with MIDI clock, in three waveforms: **sawtooth, triangle and rectangle**.

In use as a Shepard Generator, the sockets output **eight different phases each** of a **triangle** and **sawtooth** wave. Using a variety of modules, the Shepard Generator can create some interesting psycho-acoustic effects.

All A-191 settings can be **saved** into **non-volatile memory**.

2. MCV16 - Overview

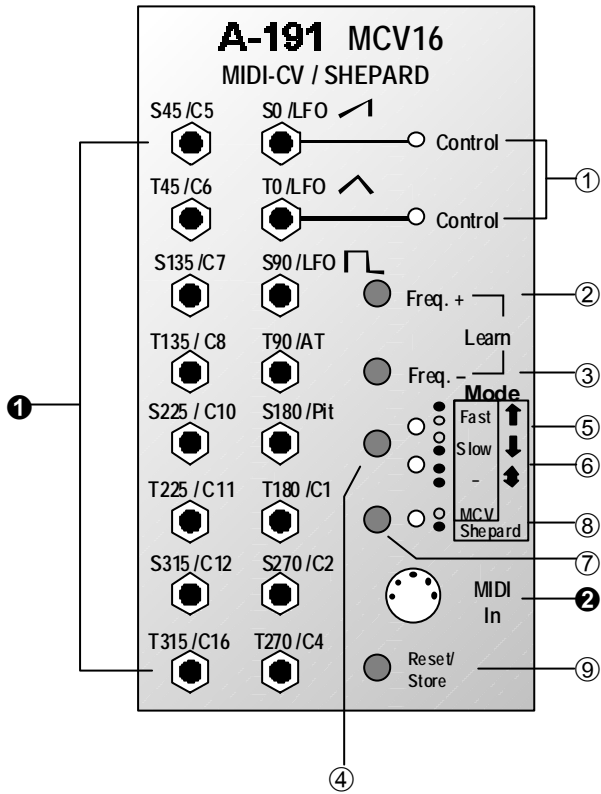

Controls and indicators

- 1 **LEDs** : Indicators for triangle and/or sawtooth waveform frequency
- 2 **Freq. +** : Button to increase LFO frequency
- 3 **Freq. -** : Button to decrease LFO frequency
- 4 **Mode** : Shepard function switch
- 5, 6 **LEDs** : Shepard function indicators
- 7 **Mode** : Switch to select either Shepard Generator or MIDI interface
- 8 **LED** : Indicator to show which out of the Shepard Generator or MIDI interface is selected
- 9 **Reset/Store** : Button for saving set-ups or resetting Shepard Function Generator

In- / Outputs

- ! **sockets** : CV outputs from the Shepard Generator and MIDI-CV interface (see text)
- " **MIDI In** : MIDI input socket

3. Switching between the functions

Because the A-191 has two separate functions in it, which share some of the controls and outputs, at any one time it can be used **either** as a MIDI-CV interface **or** as a Shepard Generator. To switch between the two you simply press a button (see below).

H The A-191's controls and in / outputs for each function are explained in their respective sections of this manual.

7 Mode button

To switch between functions, press the **lowest mode button 7**.

8 LED

LED 8 **lights** when the **Shepard Generator** is active; otherwise it's the MIDI-CV interface which is active.

H If the A-191 receives **MIDI clock**, LED 8 flashes (see chapter. 4.2, " MIDI In).

4. MIDI-CV interface

4.1 Basics

In its MIDI-CV mode, the A-191 provides a MIDI-CV converter, and a MIDI-synchronized LFO.

Whenever the A-191 receives **relevant MIDI controller messages** on the channel you've selected, it converts them into control voltages (in a 0 V to +5 V range), and sends these out on the corresponding CV outputs. Table 1 on page 4 lists the MIDI controllers, their corresponding CV output sockets, and their default values.

H After switching your A-100 system on, pressing the **Store/Reset button 9** sets the voltages at the **CV outputs** to the **default values** (see table 1).

If you're running your A-100 from a MIDI sequencer, you'll need to save the appropriate MIDI controller messages at the beginning of a Song, to initialise the A-191's CV outputs correctly.

Output	corresponding MIDI controller	default [V]
AT	After Touch	0
Pit	Pitch Wheel	2.5
C1	CTRL. #01 - Modulation Wheel	0
C2	CTRL. #02 - Breath Controller	0
C4	CTRL. #04 - Foot Controller	0
C5	CTRL. #05 - Portamento	0
C6	CTRL. #06 - Data Slider	0
C7	CTRL. #07 - Volume	5
C8	CTRL. #08 - Balance	2.5
C10	CTRL. #10 - Pan	2.5
C11	CTRL. #11 - Expression	0
C12	CTRL. #12	0
C16	CTRL. #16	0

Table 1: Valid MIDI controllers, their corresponding CV outputs, and default values.

The A-191's internal MIDI-synchronised LFO has three waveforms - sawtooth, triangle, and rectangle.

This LFO is only **active** when a **MIDI clock** is being sent to the MIDI IN, from a START or CONTINUE message until a STOP message. LED 8 indicates that it's active.

At a STOP message, the voltage at the CV output is held; at a CONTINUE message, the LFO starts from this value; and at a START message, the waveform begins again, starting from 0 V.

The LFO rate can be slowed down by dividing the clock rate. You set the **divisor** either with **MIDI controller #92** (Tremolo Depth) or manually, with buttons 2 and/or 3.

The **note length N** of a full cycle of the waveform generated by the LFO follows this formula :

$$N\text{th Note} = 1/16 \times \text{controller value (see Table 2)}$$

So, for instance, in 4/4 time, with a controller value of 8, the note length of a full LFO cycle would be half of a whole note: that is, the LFO would cycle twice for each beat in the bar (see Fig. 1).

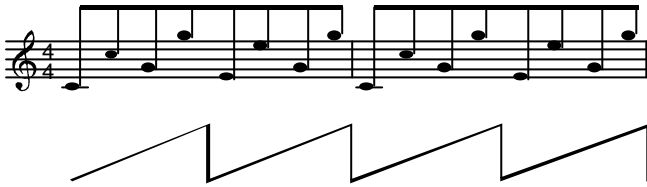

Fig. 1: The sawtooth (1/2 note cycle) generated by a MIDI controller value of 8.

Controller value	LFO cycle
0	LFO off
1	1/16
2	2/16 = 1/8
3	3/16
4	4/16 = 1/4
8	8/16 = 1/2
16	16/16 = 1 whole note
32	32/16 = 2 whole notes
64	64/16 = 4 whole notes

Table 2: Typical values for controller #92 and the resultant length of the LFO cycle.

H Because the A-191's LFO is purely a **software** device, the following considerations apply, which it's well worth remembering.

The A-191 uses an 8-bit D/A converter, whose maximum resolution is 256 steps per 0.02 V. Consequently, the **sawtooth** and **triangle** waves can't be as smooth as, for instance, those of the A-145 LFO. The waveforms on the A-191 LFO are **digital** ("stepped").

If you use it to control, eg, a VCO, the result is less of a smooth continuous pitch sweep, and much more akin to a glissando. How audible these steps are depends on the MIDI-Clock **tempo**, and the **divisor** you've chosen.

P If the steps are audible (and unwanted), you can use a **Slew Limiter** (A-171) to smooth out the waveforms.

Erratic or sudden changes of tempo or the **divisor** will take a whole note to register, before the LFO changes to this new frequency.

4.2 Indicators and controls

1 LEDs

The LEDs 1 indicate the frequency of the internal LFOs. They indicate the state of the **sawtooth** signal at output **S0** and/or the **triangle** wave at output **T0**.

2 Freq. + • 3 Freq. –

Buttons 2 and 3 have a double function in the MIDI-CV interface:

- **Setting LFO frequency**

Pressing buttons 2 or 3 **increases** and/or **decreases** the **frequency** of the internal LFOs.

While buttons 2 or 3 are pressed, **LEDs** 5 and 6 blink to show the increase or decrease in the LFO frequency. If you reach the upper or lower limit of the frequency, the LED stops blinking.

H It's easier and definitely **more precise** to alter the LFO frequency **by MIDI controller #92**.

Setting the MIDI input channel

If you simultaneously hold down buttons 2 and 3, "**learning mode**" is activated. This is signalled by LEDs 5, 6 and 8 all flashing at once.

You can now set the MIDI channel you want the MCV16 to respond to. To do this, send a valid **MIDI controller** (see table 1) to the A-191. This automatically ends learning mode, the LEDs go out, and the MIDI channel of whatever controller was used becomes the input channel for all the MIDI data sent after this.

LFO frequency and MIDI- input channel are only temporarily stored, unless you save them by pressing button 9 (see below).

H The labels on LEDs 5 and 6 ("Fast", "Slow", "--") don't have a function yet in MIDI-CV mode, but are hoped to have in a future update.

9 Reset / Store

To **save** the settings for **MIDI input channel** and **LFO frequency** press button 9.

LEDs 5, 6 and 8 light for about a second to confirm the save procedure has succeeded. At the same time, all CV outputs are set to their default settings (see table 1).

4.3 In- / Outputs

! CV outputs

Sockets ! are the MIDI-CV interface's CV outputs:

LFO  • LFO  • LFO 

These sockets are the outputs for the **sawtooth**, **triangle** and **rectangle** waves produced by the **internal LFO**. LEDs 1 and 2 give an indication of the voltages at the sawtooth and triangle wave outputs.

H Don't forget that the LFO will only work if a **MIDI clock** is being received on the selected MIDI channel (see chapter 4.1, Basics).

AT • ... • C16

These 13 sockets output the control voltages converted from their respective **MIDI controllers** (see table 1). Their voltage range is from 0 V to +5 V.

" MIDI In

This MIDI input socket should be connected to the MIDI keyboard or sequencer, etc., that you want to control the System A-100, with a standard MIDI lead.

As well as converting MIDI controllers After Touch, Pitch Wheel, #01, #02, #04 to #08, #10, #11, #12 and #16, and turning them into voltages available at the corresponding CV outputs (see table 1), the A-191 also responds to MIDI clock - and to MIDI controller #92 ("Tremolo Depth") for controlling the internal LFOs.

4.4 User examples

Modulation-rich synthesizer patch

The example in Fig. 2 shows a 'classic' synthesizer patch: **2 VCOs**, **VCF** (A-122) and **VCA** (A-130). Modules **A-190** and **A-191** act as the link to a **MIDI keyboard**, and are set to the same MIDI channel. The THRU from the A-190 is connected to the MIDI IN of the A-191.

This patch gives a **vast range of modulation possibilities** accessible from velocity, mod wheel, pedals, and aftertouch:

- **VCO 2 level**

VCO 2's amplitude level (ie. volume) can be controlled with a pedal. In this example, the **A-190's second CV output (CV 2)** has been previously programmed to respond to MIDI controller #04, but **CV output C4** on the **A-191** could have equally well been used.

- **Modulation of VCF resonance**

Filter resonance is modulated by a **random voltage source** (the **A-118's** random output). The **intensity**

of this modulation is controlled by the **modulation wheel** (output **C1** on the A-191).

- **Amplitude modulation**

The **intensity** of the amplitude modulation created by the LFO patched into the VCA (A-130) is controlled by **aftertouch** (output **AT** on the A-191).

- **Overall volume**

The overall volume of the output signal sent to the monitoring system is controlled by **MIDI controller #7 (Volume)** (output **C7** on the A-191). This controller can be assigned to a pedal, pitch ribbon, etc. on your master keyboard.

H If you want to use a MIDI controller which the A-191 doesn't support - for instance a sustain pedal - then you can always set the A-190 to respond to it, and output it from its CV2 socket.

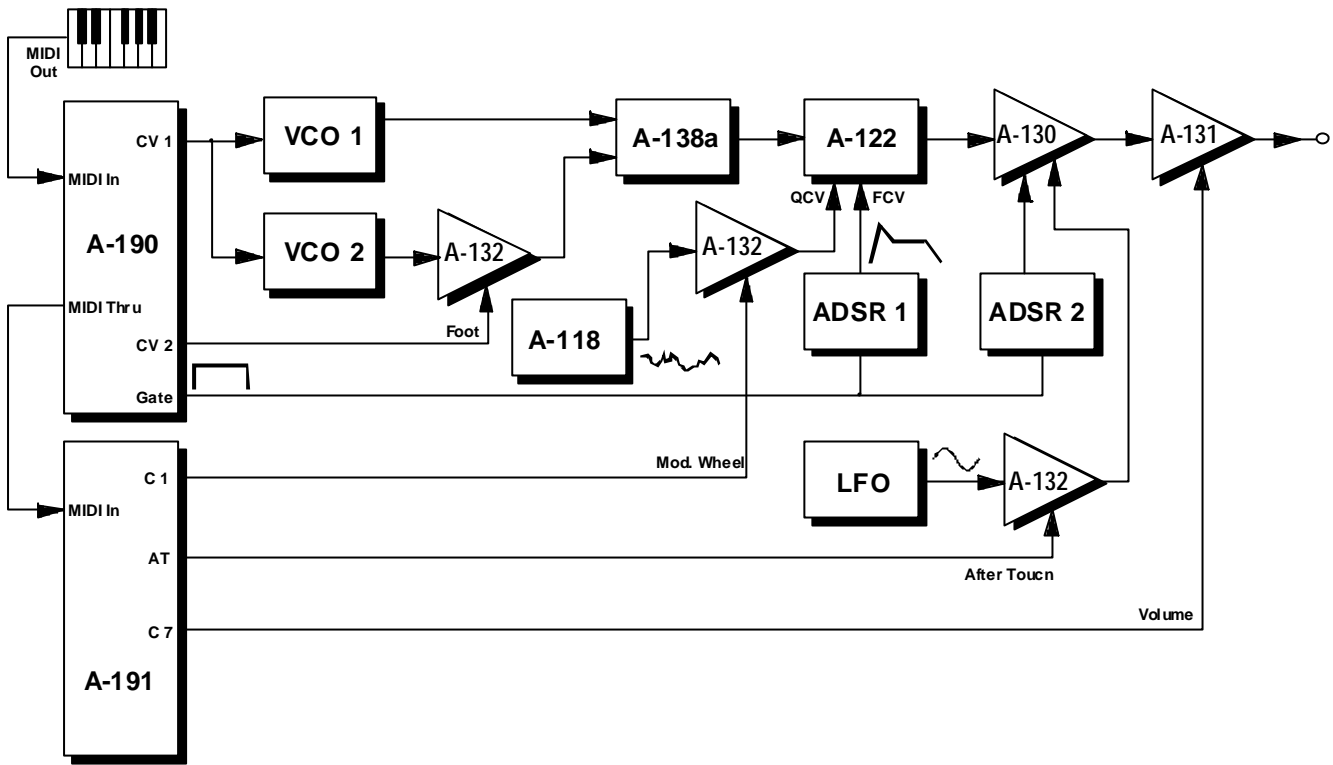

Fig. 2: Classic synthesizer patch with multiple modulation possibilities.

MIDI-synchronised LFO

The internal LFO on the A-191 is synchronised to MIDI clock. This is particularly useful when you're using a MIDI sequencer or arpeggiator with the A-100.

An example is shown in Fig. 3. In this patch, the internal LFO modulates the VCF's cut-off frequency.

Set the LFO frequency so that it completes one cycle every whole note.

During the first four 1/8th notes of the sequence, the filter is opening; and in the last four 1/8th notes, it's closing.

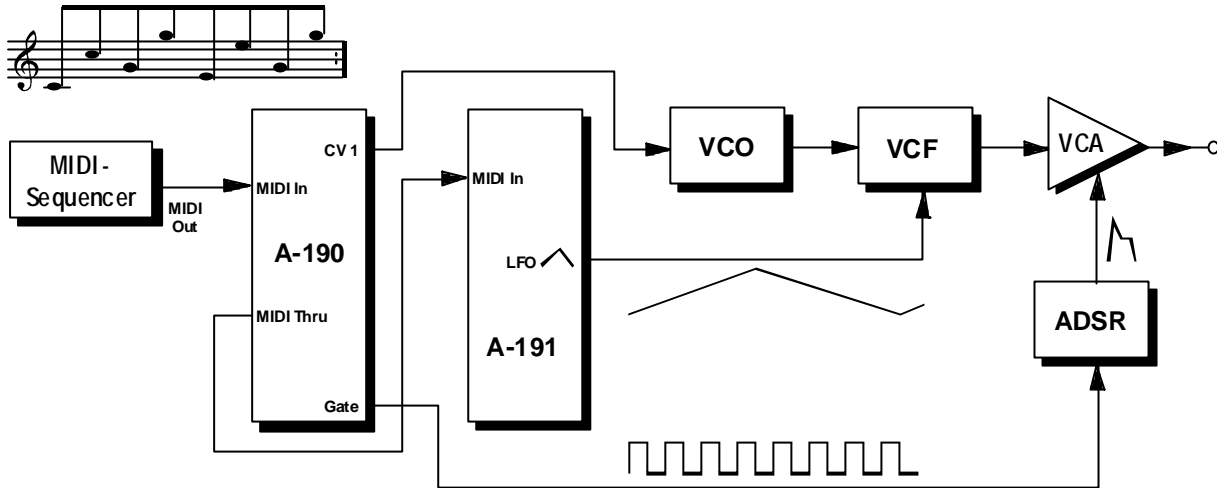

Fig. 3: VCF cutoff control with a MIDI-synced LFO.

Another example of MIDI-synchronised use of the internal LFO is shown in Fig. 5. Two A-125 phasers set to opposite phase are sent to two audio outputs (Out_L

and Out_R) to produce **MIDI-synchronised spatial effects.**

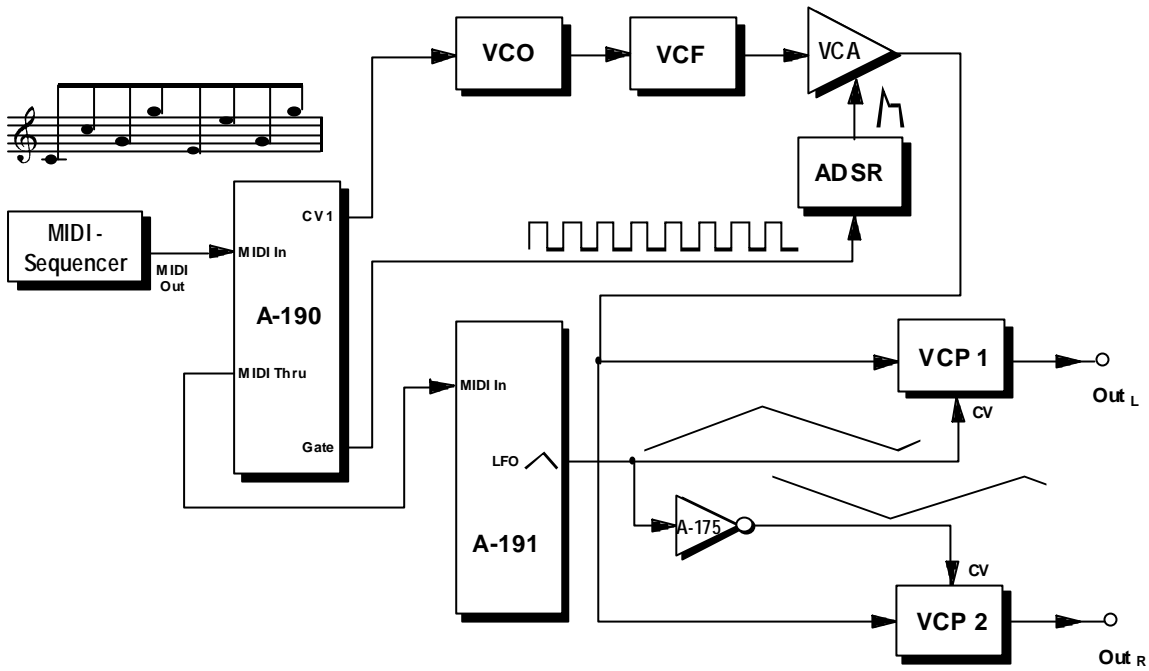

Fig. 4: MIDI-synchronised "stereo" phasing.

5. Shepard generator

5.1 Basics

A Shepard generator is a **modulation oscillator**, which produces **various phase inversions of triangle and sawtooth waveforms** at its outputs.

The way the Shepard generator is set up produces various **psycho-acoustic phenomena**, such as the 'barber-pole' effect - seemingly never-ending upward or downward spirals of pitch, filter settings, phasing, and stereo or quadraphonic sound-stage panning (see chapter 5.3, User examples).

The **triangle wave signal** is sent via outputs **T 0** to **T 315**, and the **sawtooth wave signal** is sent via outputs **S 0** to **S 315**, (where the numbers refer to the phase displacement for each output in degrees).

Fig. 5 shows this, but with only every other output included, for the sake of clarity. T_{LFO} is the time the internal LFOs take to complete one cycle.

The **Shepard mode** - the direction of the sawtooth waveform generated - is **selectable**. Fig. 5 shows the mode with a sawtooth waveform.

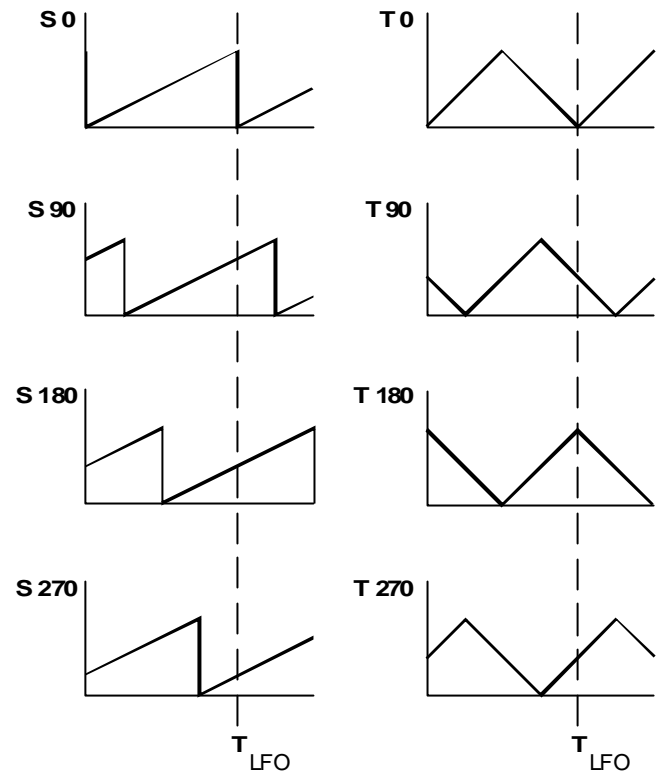

Fig. 5: Shepard generator output signals (half shown)

5.2 Indicators and controls

1 LEDs

The LEDs 1 give you a read-out of the frequency of the Shepard generators. They show the state of the **sawtooth wave** at output **S0** and/or **triangle wave** at output **T0**.

2 Freq. + • 3 Freq. –

Pressing buttons 2 or 3 **raises** and/or **lowers** the **frequency** of the Shepard generator. These settings are only temporary: if you want to **save** them, press button 9 (see below).

4 Upper mode button

Button 4 selects the **Shepard mode**, which determines the direction of the sawtooth signal generated by the Shepard generator (see table 3). The mode chosen is indicated by LEDs 5 and 6.

These settings are only temporary: if you want to **save** them, press button 9 (see below).

5 LED • 6 LED

LEDs 5 and 6 show the **Shepard mode** selected (see table 3).

Table 3: Shepard modes and LED indicators.

Mode	Effect	LED 5	LED 6
↑	8 rising sawtooth waves	on	off
↓	8 falling sawtooth waves	off	on
↕	4 rising sawtooth waves at outputs S0, S90, S180, S270; 4 falling sawtooth waves at outputs S45, S135, S225, S315	on	on

9 Reset / Store

Pressing button 9 **saves** the settings for **frequency** and **Shepard mode**. Confirmation of the save procedure is given by LEDs 5, 6 and 8 lighting up for about a second.

The instant the Shepard generator is reset, the sawtooth and triangle waves at outputs **S0** and/or **T0** start at their **zero point**.

5.2 In- / Outputs

! CV outputs

The CV output sockets ! send out sawtooth and triangle waveforms. The number on each output refers to the amount of phase displacement, in degrees:

S0 • S45 • S90 • S135 • S180 • S225 • S270 • S315

Sockets S0 to S315 output the **sawtooth** waveforms.

T0 • T45 • T90 • T135 • T180 • T225 • T270 • T315

Sockets T0 to T315 output **triangle** waveforms.

5.3 User examples

Generating "Shepard Tones"

The Shepard Tone is a **psycho-acoustic phenomenon**, that gives the impression of a continuously rising or falling tone.

Fig. 6 shows the sort of patch needed. The Shepard generator's sawtooth waveform controls the pitch of eight VCOs, all with identical settings, while the triangle outputs control 8 VCAs - one for each VCO. To hear the effect properly, the outputs from the VCAs must be patched to two mixers (2 x A-138).

The Shepard effect is pretty mind-blowing, because it seems to be producing the impossible - a never-ending upward (or downward) sweep of the note.

Although it seems almost miraculous, there's nothing mysterious about how it works. The Shepard tone contains a large amount of octave-related harmonics across the whole audio spectrum, all of which rise (or fall) together. The harmonics towards the low and high ends of the spectrum are gradually attenuated the closer they get to the ends, while those in the middle have maximum amplification.

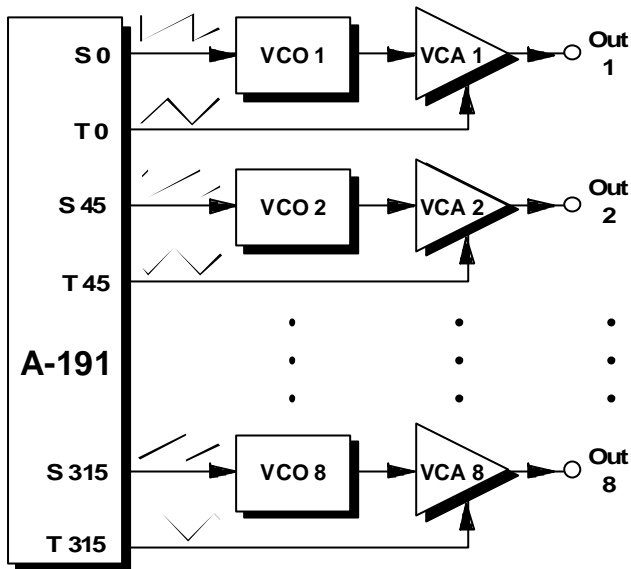

Fig. 7: Shepard tone patch

To help understand this weird science, just picture the lowest harmonic of the tone (with the Shepard generator in its "Up" mode).

It starts inaudible, but as its pitch goes up, so does its volume. By the time it gets to the middle of the audio spectrum it is at its maximum amplitude, and will then gradually get quieter again, until the highest frequency is reached, and it's inaudible again.

Meanwhile, other harmonics have been replacing it, starting very quietly at the lowest frequency.

All eight of the VCOs in the Shepard tone produce these 'layered' harmonics, re-starting at the bottom once they've reached the highest frequency. The result is, to our ears, a tone which is rising all the time, but never gets any higher! The same applies in the "down" mode, with the tone this time seeming to fall continuously.

Shepard control of signal processing modules

The Shepard generator is useful not just for these constantly rising or falling tones, but also to **control** modules which are **signal modifiers**.

Fig. 8 shows the standard patch - this time, instead of VCOs, using signal processing units, like phasers or filters, and patching an audio signal into them to be

processed. Phasers, in particular, produce a wonderfully unique effect, far richer and more animated than a standard phaser.

Alright, we have to admit that to use the Shepard generator to maximum effect does take a huge number of modules. There aren't going to be that many System A-100 owners (are there?) who have eight VCOs or VCFs or VCPs and eight VCAs to use to produce a perfect Shepard tone.

What's much more important is to **use the modules you do have creatively.**

Try all sorts of unlikely combinations of modules and control voltages.

For instance, two VCAs can produce a very nice stereo panning effect, if you use two triangle wave outputs which are 180° out of phase with each other.

With four triangle waves which are 90° out of phase with each other, and four VCAs, whose outputs are fed to a quadraphonic sound system, you can produce an interesting rotating effect (see Fig. 9).

It's worth repeating: this is one of the modules where experimentation is even more crucial than on some others.

For instance: in the patch shown in Fig. 9, try using triangle waves with different, unbalanced phase relationships, for strange spatial lurches; or phasers for 3D phasing anything is worth trying.

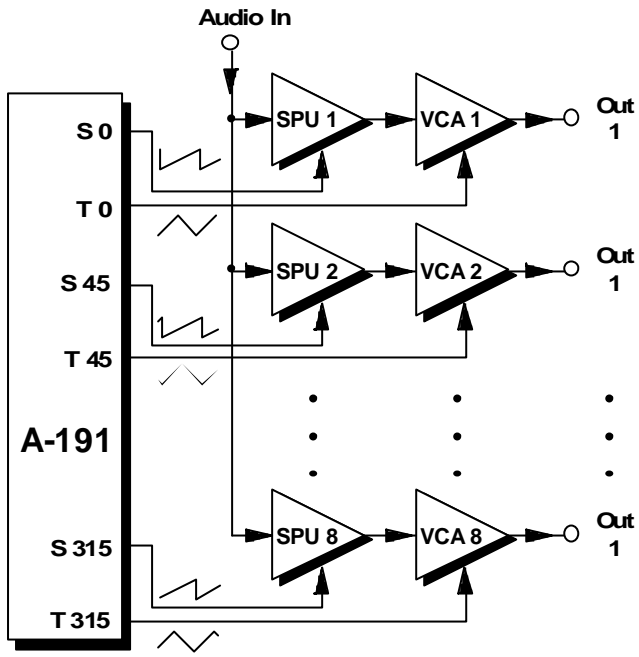

Fig. 8: Patch for Shepard control of signal processing

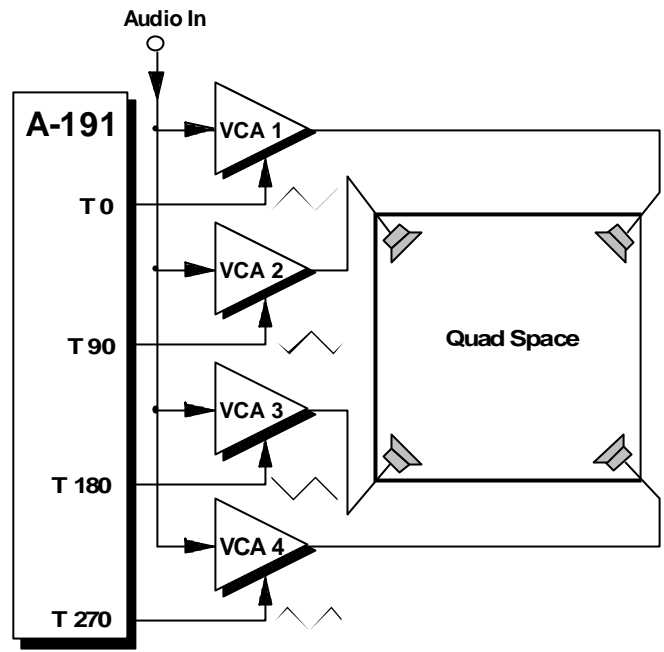

Fig. 9: Patch for quadraphonic spatial effects

6. Patch-Sheet

The following diagrams of the module can help you recall your own **Patches**. They're designed so that a complete 19" rack of modules will fit onto an A4 sheet of paper.

Photocopy this page, and cut out the pictures of this and your other modules. You can then stick them onto another piece of paper, and create a diagram of your own system.

Make multiple copies of your composite diagram, and use them for remembering good patches and set-ups.

- Draw in patchleads with colored pens.

